

F. D. HAZELTON.

CUTTER-HOLDERS FOR METAL LATHES.

No. 188,010.

Patented March 6, 1877.

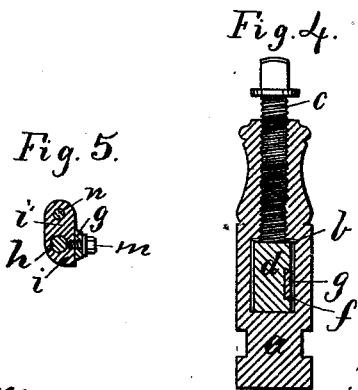
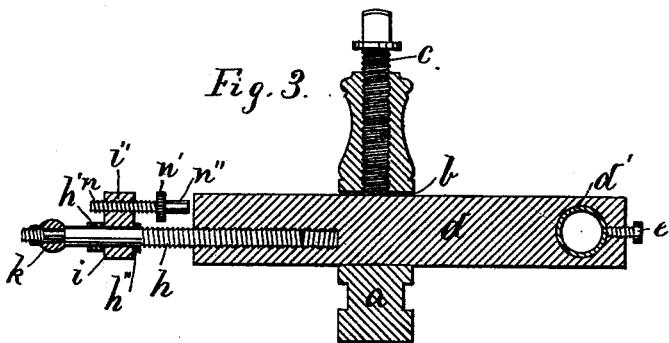
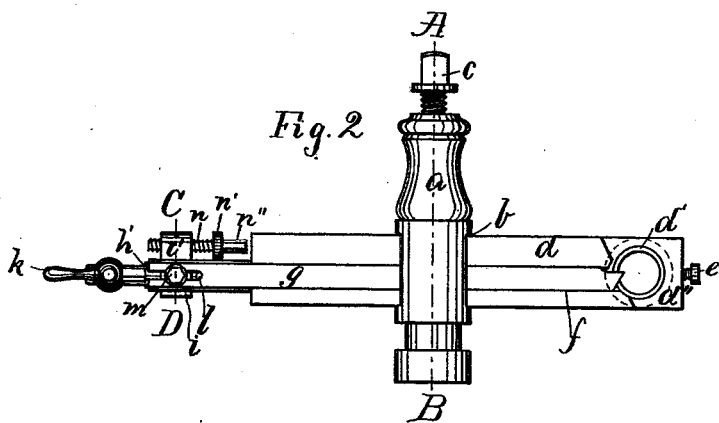
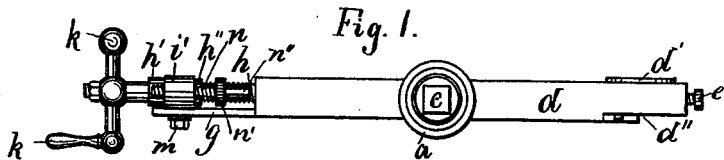

Witnesses:
 Henry Chadbourne,
 Gordon H. Nott.

Inventor:
 Frederick D. Hazelton
 by
 Alban Andrew,
 his atty.

UNITED STATES PATENT OFFICE

FREDERICK D. HAZELTON, OF BOSTON, MASSACHUSETTS.

IMPROVEMENT IN CUTTER-HOLDERS FOR METAL-LATHES.

Specification forming part of Letters Patent No. 188,010, dated March 6, 1877; application filed August 17, 1876.

To all whom it may concern :

Be it known that I, FREDERICK D. HAZELTON, of Boston, in the county of Suffolk and State of Massachusetts, have invented certain new and useful Improvements in Turning and Screw-Cutting Tools; and I do hereby declare that the following is a full, clear, and exact description thereof, which will enable others skilled in the art to which it appertains to make and use the same, reference being had to the accompanying drawings, and to letters of reference marked thereon, which form a part of this specification.

My invention relates to improvements in turning and screw cutting tools; and consists in the combination, with a grooved tool-holder, having a rest in its forward end, of an adjustable cutting-tool arranged so as to slide in the groove in the body of the tool-holder, and operated by means of a screw-spindle and a crank or hand-wheel.

In combination with the grooved tool-holder and the screw-spindle aforesaid, I use an automatic and adjustable stop, consisting of an adjustable screw-bolt passing through a projection on the feed-screw, and arranged so that its free end strikes against the tool-holder when the tool is fed forward as far as desired.

The tool-holder is secured to the ordinary tool-post in the usual way, or it may be provided with suitable lugs or projections, by which, and set-screws, the said tool-holder is secured to the bridge of the traveling tool-carriage. This improved turning and screw-cutting tool possesses several advantages over the ordinary cutting-tools now in use, in that the tool-holder can be firmly secured in its required place, and the cutting-tool can be fed forward with great precision, and automatically stopped when fed forward to the end of the desired cut; and as the tool-holder is provided in its inner end with a rest for the piece that is being turned or cut, no additional rest or guide is needed for this purpose. The rear end of the cutting-tool, being forked, and secured, by means of a screw or its equivalent, to the bearing for the feed-screw, can easily be detached and removed from its groove in the tool-holder for the purpose of repairing or sharpening it without disturbing

the true position of the tool-holder, by which arrangement a great deal of time is saved by the operator when turning cylindrical pieces, as well as in cutting screws. The rest for the piece that is being turned is shown in the drawing as a detachable annular ring secured temporarily in the end of the tool-holder, and this is the most preferable way, although a curved or V-shaped recess in the end of the said tool-holder may be employed without departing from the spirit of my invention.

For cutting screws, it may be preferable to have the groove in the tool-holder, as well as the sliding tool, arranged on the right-hand side of the tool-holder, as shown in the drawings, but for the purpose of turning ordinary pieces, I prefer to have the said groove and its sliding tool located on the opposite side of the tool-holder.

On the accompanying drawings, Figure 1 represents a plan view. Fig. 2 represents a side elevation. Fig. 3 represents a longitudinal section. Fig. 4 represents a cross-section on the line A B shown in Fig. 2, and Fig. 5 represents a cross-section on the line C D, also shown in Fig. 2.

Similar letters refer to similar parts wherever they occur on the different parts of the drawings.

a represents an ordinary tool-post, having an opening through its central portion *b*, and provided with a set-screw, *c*, in the usual manner. *d* represents my improved tool-holder, provided in its inner end with an annular detachable ring, *d'*, that serves as a rest for the piece of work that is to be turned or cut. The ring *d'* is held in place by means of the set-screw *e*, as shown. The rest *d'* may be substituted for a curved or V-shaped recess in the end of the tool-holder, if so desired.

In the side of the body or tool-holder *d* is made a groove, *f*, in which the cutting-tool *g* can slide freely in its longitudinal direction. In the rear end of the tool-holder *d* is located the screw *h*, that fits into a screw-threaded recess in the tool-holder *d*. This screw is the feed-screw for the tool *g*, and between two collars or annular projections, *h'* *h''*, on the smooth portion of the said feed-screw *h*, is located the block *i*, through which the screw *h* is made to

turn freely around its axis. The feed-screw *h* is provided in its outer end with a crank, handle, or feed-wheel, *k*, in the usual manner.

The rear end of the cutting-tool *g* is made forked, as shown at *l*, and is secured to the movable block *i* by means of the set-screw *m*, or its equivalent, such as a screw and nut, or similar device. From this it will be seen that the cutting-tool *g* can be moved with great precision from and toward the work that is being turned or cut.

The tool-holder *d* is made in its inner end with a recess, *d''*, as shown in Fig. 1, by which I am able to slide the cutting-tool out of its groove in the tool-holder when it is required to repair or sharpen the cutting-tool, and this can easily be done without in any way disturbing the position of the tool-holder *d*.

n represents a small screw-spindle, tapped in its rear end through a screw-threaded portion of the ear or projection *i'*, that forms one piece with the block *i*, heretofore described. *n'* represents an annular and serrated collar or projection on the screw or stop *n*, by which the relative position of said screw *n* to the rear of the tool-holder *d* can easily be regulated so as to limit the amount of feed of the tool according to the depth of the screw-

thread, or the depth of the cut that is desired to be turned on the work in operation.

It will be understood that this limit of the feed of the cutting-tool is arrived at when the end *n''* of the screw *n* comes in contact with the rear of the tool-holder *d*.

It is not imperative to employ the kind of tool-post *a* shown in the drawings, as my improved tool-holder *d* may be provided with ears or projections, and bolted directly to or clamped in a suitable manner to the bridge of the ordinary traveling-carriage of a lathe or screw-cutting machine.

Having thus fully described the nature, construction, and operation of my invention, I wish to secure by Letters Patent, and claim—

In combination with the grooved tool-holder *d* and its rest *d'*, the sliding cutting-tool *g*, feed-screw *h* *h'* *h''*, block *i* *i'*, and stop *n*, substantially as and for the purpose set forth and described.

In testimony that I claim the foregoing as my own invention I have affixed my signature in presence of two witnesses.

FREDERICK D. HAZELTON.

Witnesses:

ALDEN ANDRÉN,
J. F. STONE.